

- encountered in observation of nonbonded Cu-Cu distances (ref 10).
- (20) M. Cowie and M. J. Bennett, *Inorg. Chem.*, **15**, 1584 (1976).
- (21) J. R. Knox and K. Eriks, *Inorg. Chem.*, **7**, 84 (1968).
- (22) B. M. Gatehouse and P. Leverett, *J. Chem. Soc. A*, 849 (1969).
- (23) J. R. Knox and C. K. Prout, *Acta Crystallogr., Sect. B*, **25**, 1857 (1969).
- (24) G. M. Nadarian, Ph.D. Thesis, California Institute of Technology, 1957.
- (25) (a) H. Schäfer, G. Schäfer, and A. Weiss, *Z. Naturforsch. B*, **19**, 76 (1964); (b) W. P. Binnie, M. J. Redman, and W. J. Mallo, *Inorg. Chem.*, **9**, 1449 (1970); (c) P. A. Koz'min and Z. V. Popova, *Zh. Strukt. Khim.*, **12**, 99 (1971).
- (26) J. G. M. van der Aalsvoort and P. T. Bevrskens, *Cryst. Struct. Commun.*, **3**, 653 (1974).
- (27) L. Ricard, J. Estienne, P. Karagiannidis, P. Toledano, J. Fischer, A. Mitschler, and R. Weiss, *J. Coord. Chem.*, **3**, 277 (1974).
- (28) L. Ricard, C. Martin, R. Wiest, and R. Weiss, *Inorg. Chem.*, **14**, 2300 (1975).
- (29) R. Winograd, B. Spivack, and L. Dorl, *Cryst. Struct. Commun.*, **5**, 373 (1976).
- (30) L. T. J. Delbaere and C. K. Prout, *Chem. Commun.*, 162 (1971).
- (31) F. A. Cotton and R. C. Elder, *Inorg. Chem.*, **3**, 397 (1964).
- (32) E. I. Stiefel, *Prog. Inorg. Chem.*, **22**, 1 (1977).
- (33) E. I. Stiefel, W. E. Newton, G. D. Watt, K. L. Hadfield, and W. A. Bulen, "Bioinorganic Chemistry-II", *Adv. Chem. Ser.*, **162**, 353 (1977).
- (34) R. Eisenberg, *Prog. Inorg. Chem.*, **12**, 295 (1970).

## Oxygen Binding to Cobalt Porphyrins

James P. Collman,\*<sup>1</sup> John I. Brauman, Kenneth M. Doxsee, Thomas R. Halbert, Susan E. Hayes, and Kenneth S. Suslick

Contribution from the Department of Chemistry, Stanford University, Stanford, California 94305. Received August 3, 1977

**Abstract:** The thermodynamic constants of oxygen binding to cobalt "picket fence" porphyrin complexes, *meso*-tetra( $\alpha,\alpha,\alpha,\alpha$ -*o*-pivalamidophenyl)porphyrinatocobalt(II)-1-methylimidazole and 1,2-dimethylimidazole, are reported. In contrast to previously studied cobalt porphyrins, these complexes bind oxygen with the same affinity as cobalt substituted myoglobin and hemoglobin. Solvation effects are discussed as the source of this difference. The use of sterically hindered axial bases as models of T state hemoglobin is discussed.

In studies of myoglobin (Mb) and hemoglobin (Hb), the replacement of the neutral iron porphyrin prosthetic group with different metalloporphyrins has proved to be a useful technique.<sup>2</sup> Artificial hemoglobins containing zinc,<sup>2,3</sup> manganese,<sup>4-8</sup> copper,<sup>4</sup> and nickel<sup>9</sup> have been reconstituted, and their properties compared with those of the native iron proteins. These artificial systems, however, are incapable of reversible oxygenation. In contrast, cobalt substituted hemoglobin and myoglobin (CoHb and CoMb)<sup>10</sup> are functional,<sup>11-13</sup> although their oxygen affinities are 10-100 times less than those of native Hb and Mb.

CoHb exhibits cooperativity in oxygen binding, though to a lesser degree than Hb. The extent of this cooperativity is conveniently expressed as  $\Delta G_{41}^{\circ}$ , the free energy difference between the intrinsic binding of the first and the fourth O<sub>2</sub> to Hb.<sup>13b,c</sup> For CoHb,  $\Delta G_{41}^{\circ}$  is roughly one-third that of Hb under comparable conditions.<sup>13b</sup> Because of the different stereochemical and electronic factors involved in binding oxygen to a cobalt porphyrin, the observation of cooperativity in CoHb has been variously used either to question<sup>2,12,14</sup> or support<sup>13b,15</sup> the elegant proposal of Perutz concerning the molecular mechanism of cooperativity in natural Hb.<sup>16</sup> At the heart of this proposal is the assumption, based on earlier ideas of Hoard<sup>17</sup> and Williams,<sup>18</sup> that the high-spin iron in the unligated, low O<sub>2</sub> affinity form of Hb (T state) lies out of the porphyrin plane, and that on binding O<sub>2</sub>, the iron becomes low spin and moves into the plane. The resulting motion of the proximal imidazole (0.6 Å) then causes conformational changes in the protein which produce a higher O<sub>2</sub> affinity quaternary form of the protein (R state). In the deoxy form of coboglobin, cobalt is low spin rather than high spin and the best estimates from simple cobalt model systems indicate that the proximal imidazole in CoHb moves ~0.4 Å upon oxygenation<sup>14,19,20</sup> as opposed to the 0.6 Å for Hb. The resulting motion of the proximal histidine upon binding O<sub>2</sub> will therefore only be two-thirds as great. This seems to be qualitatively consistent with the lowered  $\Delta G_{41}^{\circ}$  of CoHb.

This same reasoning argues that a real tension of the Co-

N<sub>HIS</sub> bond may exist in the deoxy (T) form of CoHb. The best current explanation of cooperativity is a "restraint" theory:<sup>15a</sup> by holding the proximal imidazole in place, the T form of the native protein restrains the five-coordinate, deoxy metalloporphyrin from becoming six coordinate, *without* necessarily inducing any strain in the deoxy form of native Hb itself. In deoxy CoHb, however, the Co atom is already closer to the mean porphyrin plane than is Fe and is likely to have created a real strain in the Co-N<sub>HIS</sub> bond, which would be demonstrated as a lengthening of this bond as in structures of CoTPP(1,2-diMeIm)<sup>10</sup> compared with CoTPP(N-MeIm).<sup>10,19</sup>

In an effort to further clarify the nature of O<sub>2</sub> binding to CoHb, and, by implication, to native Hb, many workers in the last several years have investigated the reaction of simple cobalt(II) porphyrins with oxygen.<sup>2,11,21-29</sup> This work has been frustrated in most cases to date by the surprisingly low affinity of such simple cobalt(II) porphyrins for oxygen in the absence of the globin protein environment. For example, whereas CoHb has  $P_{1/2}^{\text{O}_2}$  (22 °C) of 50 Torr, CoT-*p*-OCH<sub>3</sub>PP(N-MeIm)<sup>10</sup> in toluene has  $P_{1/2}^{\text{O}_2}$  (25 °C) of 15 500 Torr.<sup>30</sup>

In a previous paper,<sup>28</sup> the synthesis of the cobalt derivative of the "picket fence" porphyrin, CoTpivPP (**1** in Figure 1) was reported, along with its *N*-methylimidazole (*N*-MeIm) adduct, **2**. It was pointed out that the five-coordinate cobalt porphyrin **2** has a fairly high O<sub>2</sub> affinity at room temperature in solution, but no thermodynamic data were obtained. We have since found that the method previously used for introduction of cobalt into the "picket fence" porphyrin resulted in rotation of the pivalamidophenyl groups ("pickets") to give a statistical mixture of atropisomers, and have therefore developed a milder technique that does not cause this rotational isomerization. In this paper, we report the improved synthesis, along with the thermodynamic constants for oxygen binding to CoTpivPP(*N*-MeIm), **2**, in the solid state and in solution. In the solid state and in toluene, this simple porphyrin is found to bind oxygen as well as CoMb. In addition, a decrease in oxygen affinity has been observed when *N*-MeIm is replaced by a

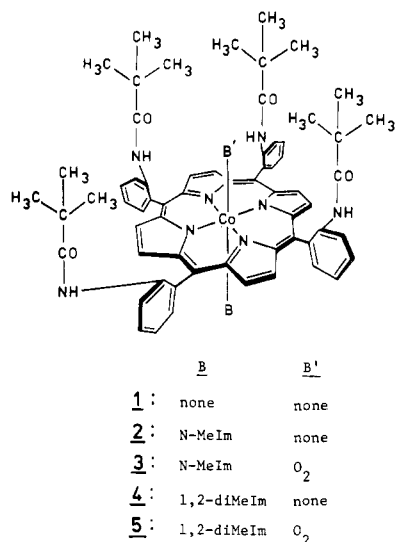

Figure 1. Cobalt "picket fence" porphyrins.

sterically hindered axial base (1,2-dimethylimidazole, 1,2-diMeIm). The importance of this observation with respect to the mechanism of cooperativity is discussed below.

### Materials and Methods

All experimental operations requiring an inert atmosphere were carried out in a Vacuum Atmospheres Co. Dri-Lab under nitrogen, unless otherwise noted. <sup>1</sup>H NMR spectra were recorded on a Varian T-60 instrument, and magnetic susceptibilities were determined by the Faraday method as previously described.<sup>31</sup> The diamagnetic correction used for the porphyrin ligand TpvPP<sup>2-</sup> was that observed for the free porphyrin H<sub>2</sub>TpvPP ( $\chi_M = 6.9 \pm 0.6 \times 10^{-4}$  cgs units). Elemental analyses were determined by the Stanford Microanalytical Laboratory. Analytical high-pressure liquid chromatography was carried out on a Du Pont 830 chromatograph with a 25 cm  $\times$  2.1 mm "Zorbax-Sil" column at 2400 psi. The column was eluted with 97.8% benzene/2% THF/0.2% ethanol and monitored with a Schoeffel UV/vis detector at 422 nm.

All solvents were distilled and stored under N<sub>2</sub>. Toluene was distilled from Na metal, THF from CaH<sub>2</sub>, and MeOH from Mg(OMe)<sub>2</sub>. DMA was stirred with BaO for 2 days, distilled under reduced pressure, and stored over Linde 4A molecular sieves. *N*-MeIm was vacuum distilled from KOH, and 2,6-lutidine was purified by passage through an alumina column, followed by distillation from BF<sub>3</sub>·Et<sub>2</sub>O. Anhydrous powdered CoCl<sub>2</sub> was heated at 100 °C under vacuum for 30 min before use.

**meso-Tetra(α,α,α,α-*o*-pivalamidophenyl)porphyrinocobalt(II), CoTpvPP, 1, Figure 1.** A solution of H<sub>2</sub>TpvPP<sup>31</sup> (0.635 g, 0.628 mmol), anhydrous CoCl<sub>2</sub> (0.647 g, 4.98 mmol), and 2,6-lutidine (0.20 mL, 17.6 mmol) in 50 mL of THF was heated under nitrogen at 50 °C for 2 h. Progress of the metal insertion was monitored by following the disappearance of visible spectral bands due to the free base (422, 526, 544, 587, and 645 nm), and the corresponding appearance of bands due to CoTpvPP (412, 524, and 555 nm (shoulder)). A small peak in the free base porphyrin due to chlorin impurities (653 nm) is also replaced by a peak (616 nm) believed to be due to a Co chlorin, which is removed during purification.

The THF was removed by trap-to-trap distillation, and the residue taken up in 1:1 benzene/dilute aqueous ammonia in air. The benzene layer, containing the orange porphyrin product, was washed twice with dilute aqueous ammonia and dried over Na<sub>2</sub>SO<sub>4</sub>. Purification was accomplished by chromatography under N<sub>2</sub> on a 1  $\times$  24 in. column of activity IV Woelm neutral alumina, eluting slowly (about 1 mL/min) with 9:1 benzene/ether. The faint leading band, containing rotational isomers, was discarded. The second band was collected in three fractions. The center fraction afforded pure CoTpvPP (0.13 g, 20% yield) found to be homogeneous by analytical high-pressure liquid chromatography. The first and third fractions (0.314 g) contained traces of free base chlorin and Co chlorin, respectively, and could be purified by further chromatography. Anal. Calcd for C<sub>64</sub>H<sub>64</sub>N<sub>8</sub>O<sub>4</sub>Co: C, 71.97; H, 6.04; N, 10.49; Co, 5.45. Found: C,

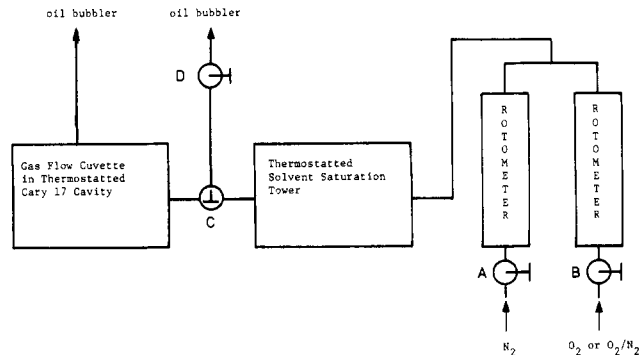

Figure 2. Solution oxygen equilibrium apparatus.

71.76; H, 6.08; N, 10.54; Co, 5.52. Magnetic susceptibility:  $\mu_{\text{eff}}$  (25 °C) = 2.2  $\mu_B$ . UV/vis  $\lambda_{\text{max}}$  (toluene) 412, 524, and 555 nm (shoulder).

**CoTpvPP(*N*-MeIm) (2).** A solution of CoTpvPP (0.305 g, 0.285 mmol) and *N*-MeIm (0.072 mL, 1.4 mmol) in 30 mL of THF was treated with four 3-mL aliquots of hexane at 30-min intervals in the inert atmosphere box. After standing for 3 days, the red-violet, crystalline product was filtered and washed with hexane and a small amount of toluene (yield 0.33 g, 100%); magnetic moment  $\mu_{\text{eff}} = 2.1 \mu_B$ ; UV/vis  $\lambda_{\text{max}}$  (toluene) 412, 508 (shoulder), 527 nm.

**CoTpvPP(*N*-MeIm)(O<sub>2</sub>) (3).** The solid dioxygen complex was prepared by exposing Co<sup>II</sup>TpvPP(*N*-MeIm) solid to oxygen (1 atm) for 24 h. Anal. Calcd for C<sub>68</sub>H<sub>70</sub>N<sub>10</sub>O<sub>6</sub>Co: C, 69.30; H, 5.97; N, 11.85; Co, 5.0. Found: C, 69.07; H, 5.23; N, 11.52; Co, 5.1. UV/vis  $\lambda_{\text{max}}$  (toluene) 412, 549 nm.

**Solid State Oxygen Equilibria.** A simple manometric adsorption apparatus used to determine oxygen absorption isotherms for solid CoTpvPP(*N*-MeIm) was essentially the same as that previously described,<sup>32</sup> consisting of a sample volume connected to a vacuum manifold and to a manometer by a three-way stopcock. The electronic manometer, a Datametrix Model 523CH-12 with ranges 0–1, 0–10, 0–100, and 0–1000 Torr with a 4.5 digit readout, was equipped with a thermostated base, and was well insulated and maintained at a constant temperature throughout the experiments. The temperature of the remainder of the apparatus was controlled to  $\pm 0.1$  °C with a constant-temperature bath. Volumes were calibrated by expanding nitrogen from an outside gas bulb of known volume, temperature, and pressure into the evacuated apparatus. Total volume of the apparatus was  $\sim 15$  mL and sample size was  $\sim 50$  mg.

Sample deoxygenation was effected by evacuating for several hours at  $10^{-6}$  Torr and  $\sim 50$  °C. Oxygen at a known pressure was then expanded from the manometer volume into the sample volume. The initial pressure drop was followed by a further decrease due to the binding of O<sub>2</sub> by the metalloporphyrin; data were collected over several hours, during which time equilibration reached  $>90\%$  of completion. The final equilibrium pressure,  $P_f$ , obtained by extrapolation of the observed pressure as a function of (time)<sup>-1</sup>, yielded the moles of oxygen adsorbed at  $P_f$  (and the fractional coverage,  $\theta$ ) as a function of pressure. Isotherms were constructed from these data at each temperature of interest using a minimum of six ( $\theta$ ,  $P_f$ ) pairs with a range in  $\theta$  from 10 to 95%, and  $P_f$  of 20 to 700 Torr.

**Solution Oxygen Equilibria.** The cell used for determination of solution oxygen equilibria consisted of a 10-mm fused silica cuvette with gas inlet and outlet tubes, by means of which N<sub>2</sub> gas containing varying partial pressures of O<sub>2</sub> can be bubbled through the porphyrin solution. The cuvette was mounted in a variable temperature holder in the cavity of a Cary 17 spectrophotometer, with an iron-constantan thermocouple attached to the side of the cuvette to monitor the temperature. For low-temperature work (below 10 °C) the cavity was flushed with argon to prevent condensation.

The entire gas flow system employed is diagrammed in Figure 2. The partial pressure of oxygen in the gas bubbled through the cuvette was adjusted by mixing pure N<sub>2</sub> with pure O<sub>2</sub> or commercially prepared O<sub>2</sub> in N<sub>2</sub> (Liquid Carbonic Certified Gas Mixtures,  $5.01 \pm 0.20$  and  $0.140 \pm 0.006\%$  oxygen in nitrogen), using two Matheson 600 rotameters and two precision needle valves (labeled A and B in the figure). The rotameters were individually calibrated throughout their ranges with both N<sub>2</sub> and O<sub>2</sub>. By use of this apparatus, partial pressures of O<sub>2</sub> could be continuously varied from 0.05 to 760 Torr.

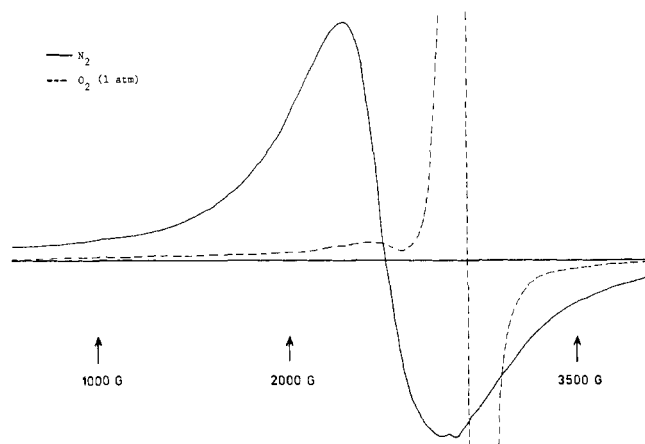

Figure 3. ESR spectra of CoTpvPP(*N*-MeIm) solid under N<sub>2</sub> and O<sub>2</sub> at 19 °C.

In order to prevent concentration changes during bubbling, the gas mixtures were saturated with solvent at the same temperature as the cuvette. Each gas mixture was passed through the cuvette until equilibrium had been attained, as indicated by constancy of absorbance (generally <5 min). The gas flow was then diverted through valve D, by means of the three-way stopcock C, while the actual spectra were run.

The concentration of Co<sup>II</sup>TpvPP in all cases was between 5 and 10 × 10<sup>-5</sup> M. Concentrations of B (B = *N*-MeIm, 1,2-diMeIm) were chosen to provide >98% Co<sup>II</sup>TpvPP(B) in solution, based on equilibrium constants for axial base binding determined under N<sub>2</sub> by standard spectrophotometric techniques.<sup>33</sup> Lack of oxidation was confirmed by bubbling pure N<sub>2</sub> through the cell at the end of each O<sub>2</sub> binding run and rerecording the deoxy spectrum.

Because oxygen binding at temperatures above 0 °C is incomplete even at 760 Torr O<sub>2</sub>, a mathematical approach which does not require knowledge of the spectrum of the pure oxygenated complex was used. This approach is a modification of one by Drago,<sup>29,33</sup> who has shown:

$$K^{-1} = P_{O_2} \left[ \frac{[Co]_{Tb} \Delta \epsilon}{\Delta A} - 1 \right]$$

where  $K$  is the equilibrium constant for O<sub>2</sub> binding to the Co(II)-porphyrin (base) complex,  $[Co]_T$  is the total porphyrin concentration,  $b$  is the path length of the cell,  $\Delta A$  is the difference between the absorbance of the solution at oxygen pressure  $P_{O_2}$ , and the absorbance of the solution in the absence of oxygen, and  $\Delta \epsilon$  is the difference between molar extinction coefficients of the oxy and the deoxy complexes. Rearranging the equation gives

$$P_{O_2} = [Co]_{Tb} \Delta \epsilon \left( \frac{P_{O_2}}{\Delta A} \right) - K^{-1}$$

from which it is clear that, since  $[Co]_{Tb} \Delta \epsilon$  is a constant, a plot of  $P_{O_2}$  vs.  $(P_{O_2}/\Delta A)$  should be a straight line with slope  $[Co]_{Tb} \Delta \epsilon$  and intercept  $-K^{-1}$ .

Sets of spectra were recorded at each temperature over a wide range of  $P_{O_2}$ , and plots of  $P_{O_2}$  vs.  $P_{O_2}/\Delta A$  were constructed for two to four wavelengths. Straight lines were then computer fit using a linear least-squares program, and equilibrium constants were determined from the intercepts.

## Results

**Co(II) Insertion.** When the free base "picket fence" porphyrin  $\alpha, \alpha, \alpha, \alpha$ -H<sub>2</sub>TpvPP is heated with excess Co(OAc)<sub>2</sub>·4H<sub>2</sub>O at 80–90 °C in DMF for 6 h, following the previously reported method, the resulting Co(II) product is found by high-pressure liquid chromatography to contain a statistical mixture of atropisomers containing only ~12%  $\alpha, \alpha, \alpha, \alpha$ -Co<sup>II</sup>TpvPP. This observation has been confirmed by comparing the <sup>1</sup>H NMR spectrum of the mixture with that of authentic  $\alpha, \alpha, \alpha, \alpha$ -Co<sup>II</sup>TpvPP (1), prepared as below. The spectrum of the pure compound exhibits a single resonance for the *tert*-butyl groups, shifted by the paramagnetic Co(II)

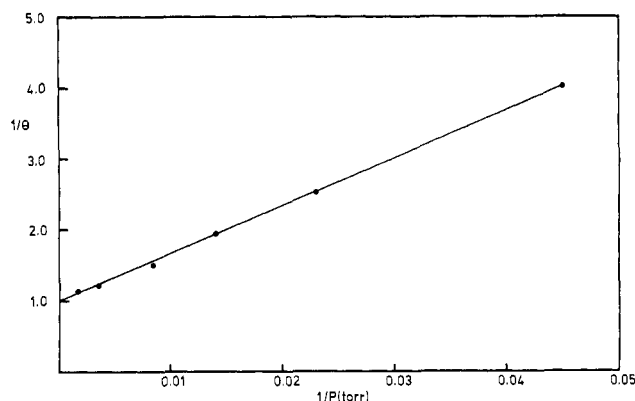

Figure 4. Langmuir isotherm for CoTpvPP(*N*-MeIm) + O<sub>2</sub> in solid state at 25 °C.

center to 5.66 ppm upfield from Me<sub>4</sub>Si. The atropisomeric mixture exhibits four peaks in this region.

The Co(OAc)<sub>2</sub>/DMF technique does not permit insertion of Co(II) into H<sub>2</sub>TpvPP efficiently at the lower temperatures necessary to avoid formation of atropisomers, and therefore a different synthetic technique had to be employed. We have found that heating a THF solution of the porphyrin at 50 °C for 2 h with excess anhydrous CoCl<sub>2</sub> and 2,6-lutidine produces moderate yields of the desired  $\alpha, \alpha, \alpha, \alpha$ -Co<sup>II</sup>TpvPP with very little isomerization. This material can be purified by chromatography on alumina, and appears to be unreactive toward oxygen in the absence of protic acids, which catalyze autoxidation.

**Solid State Oxygen Equilibrium.** The ESR spectra of crystalline Co<sup>II</sup>TpvPP(*N*-MeIm) (2) at 20 °C under N<sub>2</sub> and under 1 atm O<sub>2</sub> are illustrated in Figure 3. The spectra show that the solid is porous and that nearly complete oxygenation occurs at room temperature under 1 atm O<sub>2</sub>. This facile gas–solid equilibrium has permitted us to determine the fraction of cobalt sites oxygenated ( $\theta$ ) over a wide variety of oxygen pressures ( $P_{O_2}$ ) and temperatures, using the simple manometric technique described in the Experimental Section.

If the cobalt sites are noninteracting in the solid, isotherms constructed by plotting  $1/\theta$  vs.  $1/P_{O_2}$  should give straight lines, as described by the Langmuir equation

$$P_{1/2}(1/P_{O_2}) + 1 = 1/\theta$$

The 25 °C isotherm for solid Co<sup>II</sup>TpvPP(*N*-MeIm) is illustrated in Figure 4. Isotherms at 40 and 60 °C exhibit similar Langmuirian behavior, demonstrating that the cobalt sites are indeed noninteracting, over the range of pressure and coverage studied.  $P_{1/2}$  values were derived from the slopes of the Langmuir isotherms, and the thermodynamic enthalpy and entropy of reaction with oxygen were determined from a van't Hoff plot.  $P_{1/2}^{O_2}$  at 25 °C,  $\Delta H^\circ$ , and  $\Delta S^\circ$  are listed in Table I.

**Solution Oxygen Equilibria.** The major reactions which must be considered between cobalt porphyrins (CoP), axial bases (B), and oxygen in solution are summarized as follows:<sup>26</sup>

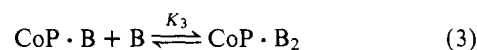
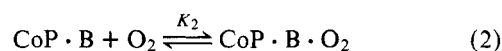
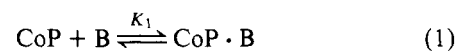

Since the reaction of interest in this study is the oxygenation reaction (2), solution conditions must be chosen under which the predominant species is CoP · B prior to addition of oxygen. With Co<sup>II</sup>TpvPP in toluene solution under N<sub>2</sub> at 20 °C,  $K_1$

**Table I.** Thermodynamic Values for O<sub>2</sub> Binding to Cobalt Porphyrins

Compd	Physical state	$P_{1/2}(25^\circ\text{C})$ , Torr	$\Delta H^\circ$ , kcal/mol	$\Delta S^\circ$ , eu <sup>a</sup>	Ref
CoMb (sperm whale)	0.1 M phosphate pH 7	57	-13.3	-40	<i>b</i>
CoMb (horse)	0.1 M phosphate pH 7	57	-11.3	-33	<i>b</i>
CoMb (sperm whale)	0.1 M phosphate pH 7	50	-11.9	-34	<i>c</i>
CoT( <i>p</i> -OCH <sub>3</sub> )PP( <i>N</i> -MeIm)	Toluene	15 500	-8.9	-36	<i>d</i>
CoPPIXDME( <i>N</i> -MeIm)	Toluene	17 800	-11.5	-45	<i>e</i>
CoPPIXDME( <i>N</i> -MeIm)	Toluene	11 000	-9.7	-38	<i>f</i>
CoTpivotPP( <i>N</i> -MeIm)	Solid	61	-13.3 ± 0.9	-40 ± 3	This work, <i>g</i>
CoTpivotPP( <i>N</i> -MeIm)	Toluene	140	-12.2 ± 0.3	-38 ± 1	This work, <i>g</i>
CoTpivotPP(1,2-diMeIm)	Toluene	900	-11.8 ± 0.4	-40 ± 2	This work, <i>g</i>

<sup>a</sup> Standard state 1 atm O<sub>2</sub>; subtract 13.2 to get standard state of 1 Torr O<sub>2</sub>. <sup>b</sup> Reference 11. <sup>c</sup> Reference 13a. <sup>d</sup> Reference 30. <sup>e</sup> Reference 34. <sup>f</sup> Reference 35. <sup>g</sup> Footnote 38.

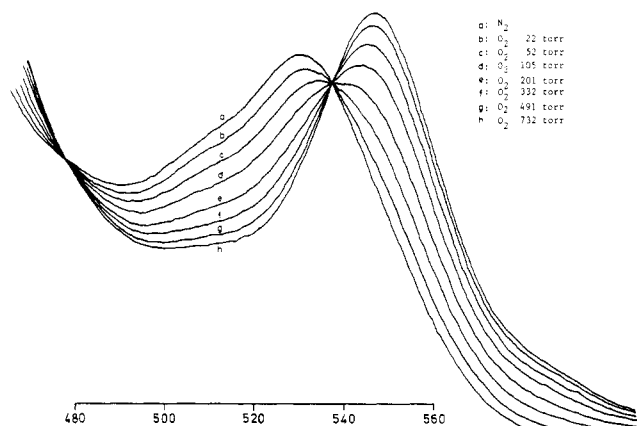
**Figure 5.** CoTpivotPP(*N*-MeIm) + O<sub>2</sub> in toluene solution at 25 °C.

is found to be  $\sim 1.7 \times 10^4 \text{ M}^{-1}$  for *N*-MeIm and  $\sim 1.4 \times 10^3 \text{ M}^{-1}$  for 1,2-diMeIm. In neither case was any evidence found for formation of six-coordinate Co<sup>II</sup>P · B<sub>2</sub> (reaction 3), and  $K_3$  must therefore be  $< 10$ . These observations are in keeping with previous work on the binding of imidazoles to cobalt porphyrins.<sup>25,26</sup> Since  $K_1 \gg K_3$ , solutions in which the predominant species is the desired Co<sup>II</sup>TpivotPP(B) can be prepared by judicious use of excess B.

The ESR parameters of Co<sup>II</sup>TpivotPP(*N*-MeIm) at 77 K in toluene under N<sub>2</sub> and under O<sub>2</sub> are compared to those for other Co(II) porphyrins in Table II. The values observed for the "picket fence" porphyrin under O<sub>2</sub> are typical for mononuclear O<sub>2</sub> complexes. Binuclear Co<sub>2</sub>-O<sub>2</sub> complexes do not exhibit an ESR spectrum.<sup>21,26</sup>

In order to determine the thermodynamic values associated with the oxygenation of Co<sup>II</sup>TpivotPP(B) solutions, visible spectra were recorded over a wide range of oxygen partial pressures and temperatures using the apparatus described in the Experimental Section. Typical sets of spectra for Co<sup>II</sup>TpivotPP(*N*-MeIm) and Co<sup>II</sup>TpivotPP(1,2-diMeIm) in toluene at 25 °C are shown in Figures 5 and 6. In all cases, good isosbestic points were observed. At 25 °C,  $\lambda_{\text{max}}$  were observed for CoTpivotPP(*N*-MeIm) at 530 nm and for O<sub>2</sub>CoTpivotPP(*N*-MeIm) at 547 nm, with isosbestic points at 478, 538, and 667 nm; for CoTpivotPP(1,2-diMeIm) at 529 nm, and for O<sub>2</sub>CoTpivotPP(1,2-diMeIm) at 546 nm, with isosbestic points at 486, 540, and 665 nm. The spectroscopic information was analyzed following the procedure outlined in the Experimental Section, to yield  $P_{1/2}$  and  $K_2$  values ( $1/K_2 = P_{1/2}$ ) between -16 and 25 °C. Thermodynamic  $\Delta H^\circ$  and  $\Delta S^\circ$  values were then derived from least-squares fits to standard van't Hoff plots;<sup>38</sup> the results are summarized in Table I. To test the effect of more polar solvent environments,  $P_{1/2}$ 's were also determined at 25 °C for CoTpivotPP(*N*-MeIm) in 1:1 toluene/MeOH ( $P_{1/2} = 430$  Torr) and in 61:39 toluene/DMA ( $P_{1/2} = 217$  Torr). The

**Table II.** ESR Parameters for Cobalt(II) Porphyrins at 77 K

System	$g_{\perp}$	$g_{\parallel}$	$ A_{\parallel}^{\text{Co}} $ , G	Ref
CoMb (sperm whale) <sup>a</sup>	2.32	2.03	75	<i>c</i>
+ O <sub>2</sub>	2.01	2.08	16	<i>c</i>
CoPPIXDME	2.32	2.03	76.5	<i>d</i>
( <i>N</i> -MeIm) <sup>b</sup> + O <sub>2</sub>	1.99	2.08	16.7	<i>d</i>
CoT( <i>p</i> -OCH <sub>3</sub> )PP( <i>N</i> -MeIm) <sup>b</sup>	2.31	2.03	75.9	<i>e</i>
+ O <sub>2</sub>	2.00	2.08	16.2	<i>e</i>
CoTpivotPP( <i>N</i> -MeIm) <sup>b</sup>	2.31	2.04	78	This work
+ O <sub>2</sub>	2.01	2.09	~20	This work

<sup>a</sup> In aqueous pH 7 buffer. <sup>b</sup> In toluene. <sup>c</sup> Reference 36. <sup>d</sup> Reference 37. <sup>e</sup> Reference 21.

toluene-DMA ratio was chosen to give roughly the same net solution dielectric as 1:1 toluene/MeOH (i.e., ~20).

## Discussion

The data presented in Table I reveal several interesting points. While previous studies of simple cobalt porphyrins have not reproduced the thermodynamic behavior of CoMb, our work clearly does. This discrepancy has two plausible explanations: first, that the "pickets" of our porphyrin provide a bonding interaction nonexistent in other simple porphyrins, or second, that the "pickets" control solvation effects which would otherwise disfavor oxygenation.

The special stabilization of the Co-O<sub>2</sub> called for in the first explanation might be due to hydrogen bonding, dispersion forces, or pocket polarity. However, a counterexample exists: CoTPP attached to a polystyrene supported imidazole appears to bind oxygen in the solid state with greater avidity than in free solution.<sup>28</sup> In this case, none of the above interactions are likely to be significant. This observation, however, is of a qualitative nature only. The final test of this explanation awaits the synthesis of a "picket fence" porphyrin with different "pickets."

The second explanation appears more tenable: simple, flat cobalt porphyrins are better solvated by toluene in their deoxy form, particularly at low temperatures. In cases where the solvation cannot change significantly upon oxygenation (e.g., CoMb, CoTpivotPP(*N*-MeIm), and CoTPP(Im-polystyrene)), this effect is of course not observed. It would appear that the unprotected cobalt porphyrins are better solvated as the five-coordinate CoP(B) than the six-coordinate CoP(B)(O<sub>2</sub>) by 2-4 kcal/mol, in the temperature range examined by previous workers ( $\sim -50$  °C).<sup>22,23,26</sup>

The importance of this selective solvation will vary from solvent to solvent in the unprotected porphyrins, making analysis of polarity effects on the Co-O<sub>2</sub> system treacherous. Only for protected porphyrins can such effects be safely interpreted; again a "picket fence" of different polarity would prove informative. In the case of CoTpivotPP(*N*-MeIm), the bulk dielectric has little effect: the change from a dielectric

**Table III.**  $P_{1/2}$  for  $O_2$  Binding to Cobalt Porphyrins

System	Physical state	$P_{1/2}(15^\circ\text{C}), \text{Torr}$	Ref
CoMb (sperm whale)	0.1 M $\text{PO}_4^{2-}$ , pH 7	24	c
CoHb (isolated chains)	0.1 M $\text{PO}_4^{2-}$ , pH 7.4	25	d
CoHb (human, R state <sup>a</sup> )	0.1 M $\text{PO}_4^{2-}$ , pH 7.4	20	d
	2 mM IHP, 0.05 M Bistris, pH 7.4	125	d
CoHb (human, T state <sup>a</sup> )	0.1 M $\text{PO}_4^{2-}$ , pH 7.4	160	d
	2 mM IHP, 0.05 M Bistris, pH 7.4	800	d
Co(TpivPP)( <i>N</i> -MeIm)	Solid	29 <sup>b</sup>	This work
	Toluene	70 <sup>b</sup>	This work
Co(TpivPP)(1,2-diMeIm)	Toluene	270 <sup>b</sup>	This work
CoT( <i>p</i> -OCH <sub>3</sub> )PP	Toluene	10 000 <sup>b</sup>	e

<sup>a</sup> These actually are the first and fourth intrinsic  $P_{1/2}$  values. <sup>b</sup> Interpolated from reported  $\Delta H^\circ$  and  $\Delta S^\circ$ . <sup>c</sup> Reference 13a. <sup>d</sup> Reference 13b. <sup>e</sup> Reference 30.

constant of 2.4 (toluene) to one of  $\sim 20$  (methanol/toluene or DMA/toluene) *decreases* the oxygen affinity slightly (a factor of  $\sim 2$  in  $P_{1/2}$ ). It is clear then that even the "picket fence" porphyrin is not *totally* immune to differential solvation effects: as seen above, relatively slight changes in  $O_2$  affinity can be induced by changing from the solid state to various solvents.

Support for the concept of solvation control is found in the solid-state study of imidazole-polystyrene CoTPP.<sup>28</sup> The greater  $O_2$  affinity of this system, in comparison to its toluene solution analogue,<sup>30</sup> is probably due to the control of solvation; i.e., in the solid polymer, solvation of deoxy and oxy forms should not differ significantly. None of the special interactions invoked in the first explanation are viable in this system. Further confirmation comes from spectroscopic observation of  $\pi$  complexes of four-coordinate cobalt porphyrins with both  $\pi$  acceptors and  $\pi$  donors.<sup>39</sup> Particularly at the low temperatures used in earlier studies of oxygenation of cobalt porphyrins, strong  $\pi$  complexes ( $\Delta H^\circ$  being as exothermic as  $-6$  kcal/mol)<sup>39d</sup> can be found with a variety of aromatic compounds (including toluene<sup>39c</sup>), the geometry of which must interfere with oxygenation.<sup>39b</sup>

In dealing with the thermodynamic data presented in Table I, it is important to realize the compensatory nature of calculated  $\Delta H^\circ$  and  $\Delta S^\circ$ . As has been noted before,<sup>29</sup> if an inadequate temperature range is used, very large, correlated errors can creep into the calculated  $\Delta H^\circ$ ,  $\Delta S^\circ$  pair; a more negative  $\Delta H^\circ$  is compensated for by a more negative  $\Delta S^\circ$  or vice versa. Thus for the CoMb's shown in Table I it is likely that all three are adequately described with  $\Delta H^\circ \approx -12.5$  kcal/mol and  $\Delta S^\circ \approx -37$  eu (standard state 1 atm). Hence, care must be taken to avoid overinterpretation of such data.<sup>40</sup> Similarly, the unprotected cobalt porphyrins are well represented by  $\Delta H^\circ \approx -10$  kcal/mol and  $\Delta S^\circ \approx -39$  eu (standard state 1 atm). In line with the above averages is the  $\Delta S^\circ$  predicted on statistical mechanical grounds.<sup>32</sup> Because of the greater temperature range possible for CoTpivPP in toluene than for the proteins in aqueous solution, and the greater affinity shown compared to the unprotected porphyrins, our data are less prone to these problems.

Further comparisons between the model system, CoTpivPP, and the cobalt hemoproteins are made in Table III. Very recent data on CoHb (collected at  $15^\circ\text{C}$ ) provide the basis for direct comparisons with the "picket fence" porphyrin complexes. The oxygen affinities of CoMb, CoHb isolated  $\alpha$  or  $\beta$  chains, and CoHb in its high-affinity R form are essentially the same as that of CoTpivPP(*N*-MeIm). Importantly, the steric hindrance provided by the 2-methyl group of 1,2-diMeIm is sufficient to decrease the oxygen affinity of CoTpivPP to the same level as the low-affinity, T form of CoHb.

The Hoard-Perutz mechanism of cooperativity proposes that there exists a restraint placed on the proximal imidazole

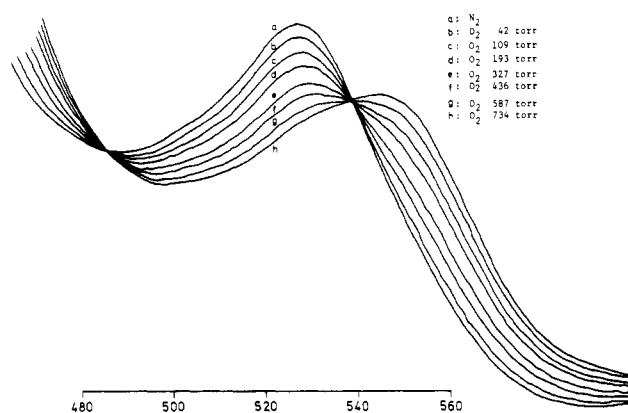

**Figure 6.** CoTpivPP(1,2-diMeIm) +  $O_2$  in toluene solution at  $25^\circ\text{C}$ .

in the T state. This restraint opposes the motion of the metal into the porphyrin plane (a motion of  $\sim 0.4$  Å for Co) upon oxygenation, and thus lowers the oxygen affinity. In the high oxygen affinity, R state, this restraint is removed. In the sense that the 2-methyl group of 1,2-diMeIm provides restraint to the motion of this axial base toward the porphyrin plane, CoTpivPP(1,2-diMeIm) is a model for the T form of CoHb. This correlation provides evidence on a microscopic scale that steric restraint of an axial base *can* decrease the oxygen affinity of a metalloporphyrin. The correspondence between our models'  $\Delta\Delta G^\circ$  (0.8 kcal/mol) and  $\Delta G^\circ_{41}$  for CoHb (0.6–1.7 kcal/mol, depending on conditions<sup>13b</sup>) is happenstance,<sup>40b</sup> since more highly restrained bases such as 2-isopropylimidazole or 1,2,4,5-tetramethylimidazole, for example, should show even greater  $P_{1/2}$ 's; work is in progress. The crystal structure of CoTPP(1,2-diMeIm) confirms the expected steric interactions between the imidazole and the porphyrin ring.<sup>19</sup>

An interesting prediction can be made concerning similar model studies on Fe(TpivPP). Since the metal atom is further out of the mean porphyrin plane for five-coordinate iron(II) than cobalt(II),<sup>14,15,17,19,20</sup> one expects a greater change in the steric interaction of a bound 1,2-diMeIm for the iron(II) than cobalt(II) upon oxygenation. Hence, we expect a greater increase in  $P_{1/2}$  for Fe(TpivPP)(B) than for CoTpivPP(B) in changing B from *N*-MeIm to 1,2-diMeIm. This is completely analogous to the lessened cooperativity shown by CoHb relative to native Hb.

### Summary

CoHb and CoMb show much higher oxygen affinities than previously studied simple cobalt porphyrins. In contrast, the "picket fence" system CoTpivPP(*N*-MeIm) exhibits the same thermodynamic constants for binding  $O_2$  as these cobalt hemoproteins. This is apparently due to a control of solvation in CoHb, CoMb, and CoTpivPP(*N*-MeIm), which is lacking in

other cobalt porphyrins, rather than a special interaction between O<sub>2</sub> and the apoprotein.<sup>11</sup> The restraint presumed present in the T form of CoHb has been well modeled by Co(T-pivPP)(1,2-diMeIm) and provides evidence on a molecular level that the Hoard-Perutz mechanism is viable.<sup>41</sup>

**Acknowledgment.** We thank the Fannie and John Hertz Foundation for fellowship support (K.S.S.), the National Science Foundation, Grant CHE75-17018, and the National Institutes of Health, Grant GM17880.

## References and Notes

- (1) To whom correspondence should be addressed.
- (2) (a) F. Basolo, B. M. Hoffman, and J. A. Ibers, *Acc. Chem. Res.*, **8**, 384 (1975); (b) B. M. Hoffman, *J. Am. Chem. Soc.*, **97**, 1688 (1975), and references cited therein.
- (3) J. Leonard, T. Yonetani, and J. B. Calles, *Biochemistry*, **13**, 1461 (1974).
- (4) T. L. Fabry, C. Simo, and K. Javaherian, *Biochim. Biophys. Acta*, **160**, 118 (1968).
- (5) T. Yonetani, H. R. Drott, J. S. Leigh, Jr., G. H. Reed, M. R. Waterman, and T. Asakura, *J. Biol. Chem.*, **245**, 2998 (1970).
- (6) K. Moffat, R. S. Loe, and B. M. Hoffman, *J. Am. Chem. Soc.*, **96**, 5259 (1974).
- (7) (a) C. Bull, R. G. Fisher, and B. M. Hoffman, *Biochem. Biophys. Res. Commun.*, **59**, 140 (1974); (b) Q. H. Gibson, B. M. Hoffman, R. H. Crepeau, S. J. Edelstein, and C. Bull, *ibid.*, **59**, 146 (1974).
- (8) B. M. Hoffman, Q. H. Gibson, C. Bull, R. H. Crepeau, S. J. Edelstein, R. G. Fisher, and M. J. McDonald, *Ann. N.Y. Acad. Sci.*, **244**, 174 (1975).
- (9) J. E. O'Hagen, "Haematin Enzymes", Pergamon Press, Oxford, 1961, p 173.
- (10) Abbreviations used in this paper include: CoHb, apohemoglobin reconstituted with CoPPIX; CoMb, apomyoglobin reconstituted with CoPPIX; DMA, *N,N*-dimethylacetamide; 1,2-diMeIm, 1,2-dimethylimidazole; Hb, hemoglobin; IHP, inositol hexaphosphate; Mb, myoglobin; NMeIm, 1-methylimidazole;  $P_{1/2}^O$ , oxygen pressure at half saturation; PPIXDME, protoporphyrinate IX dimethyl ester; T-pivPP, *meso*-tetra( $\alpha,\alpha,\alpha,\alpha$ -*p*-ivalamidophenyl)porphyrinate; T(*p*-OCH<sub>3</sub>)PP, *meso*-tetra(*p*-methoxyphenyl)porphyrinate; TPP, *meso*-tetraphenylporphyrinate;  $\theta$ , fractional occupation of Fe sites by O<sub>2</sub>.
- (11) (a) B. M. Hoffman and D. H. Petering, *Proc. Natl. Acad. Sci. U.S.A.*, **67**, 637 (1970); (b) C. A. Spilburg, B. M. Hoffman, and D. H. Petering, *J. Biol. Chem.*, **247**, 4219 (1972).
- (12) B. M. Hoffman, C. A. Spilburg, and H. H. Petering, *Cold Springs Harbor Symp. Quant. Biol.*, **36**, 343 (1971).
- (13) (a) T. Yonetani, H. Yamamoto, and G. V. Woodrow, *J. Biol. Chem.*, **249**, 682 (1974); (b) K. Imai, T. Yonetani, and M. Ikeda-Saito, *J. Mol. Biol.*, **109**, 83 (1977); (c) H. A. Saroff and A. P. Minton, *Science*, **175**, 1253 (1972).
- (14) R. G. Little and J. A. Ibers, *J. Am. Chem. Soc.*, **96**, 4452 (1974).
- (15) (a) M. F. Perutz, *Br. Med. Bull.*, **32**, 195 (1976); (b) W. H. Woodruff, T. G. Spiro, and T. Yonetani, *Proc. Natl. Acad. Sci. U.S.A.*, **71**, 1065 (1974).
- (16) M. F. Perutz, *Nature (London)*, **228**, 726 (1970).
- (17) J. L. Hoard in "Hemes and Hemoproteins", B. Chance, R. W. Estabrook, and T. Yonetani, Ed., Academic Press, New York, N.Y., 1966, p 9.
- (18) R. J. P. Williams, *Fed. Proc., Fed. Am. Soc. Exp. Biol., Suppl. 10*, **20**, 5 (1961).
- (19) (a) J. L. Hoard and W. R. Scheidt, *Proc. Natl. Acad. Sci. U.S.A.*, **70**, 3919 (1973); (b) W. R. Scheidt, P. N. Dwyer, and P. Madura, *J. Am. Chem. Soc.*, **96**, 4815 (1974).
- (20) R. G. Little and J. A. Ibers, *J. Am. Chem. Soc.*, **96**, 4440 (1974).
- (21) F. A. Walker, *J. Am. Chem. Soc.*, **92**, 4235 (1970).
- (22) H. C. Stynes and J. A. Ibers, *J. Am. Chem. Soc.*, **94**, 1559 (1972).
- (23) D. V. Stynes, H. C. Stynes, B. R. James, and J. A. Ibers, *J. Am. Chem. Soc.*, **95**, 1796 (1973).
- (24) H. C. Stynes and J. A. Ibers, *J. Am. Chem. Soc.*, **94**, 5125 (1972).
- (25) F. A. Walker, *J. Am. Chem. Soc.*, **95**, 1150 (1973).
- (26) F. A. Walker, *J. Am. Chem. Soc.*, **95**, 1154 (1973).
- (27) F. S. Molinaro, R. G. Little, and J. A. Ibers, *J. Am. Chem. Soc.*, **99**, 5628 (1977).
- (28) J. P. Collman, R. R. Gagné, J. Kouba, and H. Ljusberg-Wahren, *J. Am. Chem. Soc.*, **96**, 6800 (1974).
- (29) T. J. Beugelsdijk and R. S. Drago, *J. Am. Chem. Soc.*, **97**, 6466 (1975).
- (30) Calculated from the thermodynamic data in ref 26.
- (31) J. P. Collman, R. R. Gagné, C. A. Reed, T. R. Halbert, G. Lang, and W. T. Robinson, *J. Am. Chem. Soc.*, **97**, 1427 (1975).
- (32) J. P. Collman, J. I. Brauman, and K. S. Suslick, *J. Am. Chem. Soc.*, **97**, 7185 (1975).
- (33) (a) R. S. Drago, "Physical Methods in Chemistry", W. B. Saunders, Philadelphia, Pa., 1977, p 88; (b) N. J. Rose and R. S. Drago, *J. Am. Chem. Soc.*, **81**, 6138 (1959).
- (34) Calculated from the thermodynamic data in ref 22.
- (35) P. Cannady and R. S. Drago, private communication.
- (36) T. Yonetani, H. Yamamoto, and T. Iizaka, *J. Biol. Chem.*, **249**, 2168 (1974).
- (37) D. V. Stynes, H. C. Stynes, J. A. Ibers, and B. R. James, *J. Am. Chem. Soc.*, **95**, 1142 (1973).
- (38) (a) Data for van't Hoff plots ( $T$  in °C,  $\ln K_{eq}$  in atm<sup>-1</sup>): CoT-pivPP(*N*-MeIm), solid state (60.0, 0.0617) (40.0, 1.481) (25.0, 2.404); CoT-pivPP(*N*-MeIm), in toluene (27.0, 1.448) (24.9, 1.534) (24.7, 1.523) (8.2, 2.779) (-2.8, 3.706) (-12.6, 4.379) (-12.8, 4.69); CoT-pivPP(1,2-diMeIm), in toluene (24.9, -0.234) (24.5, -0.022) (4.9, 1.159) (-12.3, 2.674) (-13.8, 2.703) (-15.8, 3.122). Relative standard deviations of calculated  $P_{1/2}$  were generally between 1 and 5%. Error limits given  $\Delta H^\circ$  and  $\Delta S^\circ$  were the standard deviation of the van't Hoff plots. (b) Analysis of our raw spectra by a similar but not identical technique<sup>29,33</sup> gives the same  $P_{1/2}$  to within half the standard deviation: R. S. Drago and P. Cannady, personal communication.
- (39) (a) G. N. LaMar and F. A. Walker, *J. Am. Chem. Soc.*, **95**, 1790 (1973); (b) C. D. Barry, H. A. O. Hill, B. E. Mann, R. J. Sadler, and R. J. P. Williams, *ibid.*, **95**, 4545 (1973); (c) F. A. Walker, *J. Magn. Reson.*, **15**, 201 (1974); (d) G. P. Fulton and G. N. LaMar, *J. Am. Chem. Soc.*, **98**, 2119 (1976); (e) *ibid.*, **98**, 2124 (1976).
- (40) (a) Comparisons between hemoproteins in water and synthetic analogues in organic solvents (or solid state) are best made with equilibrium constants expressed in terms of O<sub>2</sub> pressure. We compare these equilibria:
 
$$(O_2)_{gas} + (analogue)_{solvent} \rightleftharpoons (O_2 \cdot analogue)_{solvent}$$

$$(O_2)_{gas} + (protein)_{H_2O} \rightleftharpoons (O_2 \cdot protein)_{H_2O}$$
 Treated in this manner, O<sub>2</sub> does not enter into the thermodynamic comparison. If the equilibria are expressed in terms of dissolved O<sub>2</sub> (e.g., M<sup>-1</sup>), however, then its change in solvation free energy between different solvents will obscure the comparison. When equilibria are expressed in terms of O<sub>2</sub> pressure, the solvation of O<sub>2</sub> is irrelevant: regardless of the dissolved gas concentration, at a given O<sub>2</sub> pressure, the chemical potential of O<sub>2</sub> will be the same in all solvents. (b) In comparison between Hb and model compounds,  $\Delta G^\circ_{41}$  or, equivalently, the intrinsic stepwise equilibrium constants<sup>13c</sup> of Hb should be used. The Adair constants, if not corrected for the statistics of the situation, will exaggerate the differences in the intrinsic O<sub>2</sub> affinity of a single heme within the tetramer as the change from the T state (low affinity) to the R state (high affinity) occurs.
- (41) NOTE ADDED IN PROOF. Since submission of this paper, we have extended this work to ferrous porphyrins: *Proc. Natl. Acad. Sci. U.S.A.*, in press.